

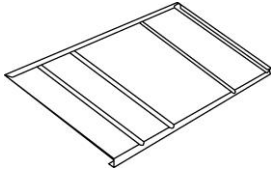

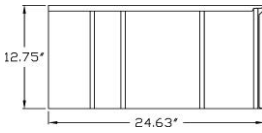
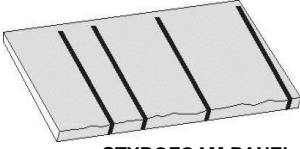
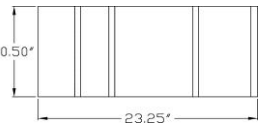

# Great American Shake Steel

PART NO.	PRODUCT	DIMENSIONS	SPECIFICATIONS & PACKAGING
5401	 GREAT AMERICAN SHAKE		Exposure 24"x12" Butt: 1 1/8" Per Carton: 25 panels Coverage: 1/2 square Gross Weight: 40 lbs.  <b>Residential &amp; light commercial use.</b>
4024	 STYROFOAM PANEL INSERT		24"x12" <b>Sold by 2 squares only.</b> <b>Used one per panel in areas requiring extra rigidity.</b>
5402	 EAVE STARTER STRIP		Length: 12' Per Carton: 10 pieces 120 lineal feet Gross Weight: 40 lbs.  <b>One-piece starter/drip combination</b>
5407	 RIDGE CAP		Length: 12' Butt 1/4" Per Carton: 60 pieces Gross Weight: 40 lbs. <b>For roof peaks &amp; mismatched hips. Ridges and hips must be watertight before 5407 installation.</b>
5408	 HIP CAP		Coverage: One Course Butt 1 1/8" Per Carton: 40 pieces Gross Weight: 40 lbs.  <b>For hips with equal roof pitches.</b>
5417	 GABLE EDGE TRIM		Length: 12' Per Carton: 5 pieces 60 lineal feet Gross Weight: 35 lbs. <b>Used as an alternative to the 5427 Gable Channel.</b>
5425	 OPEN VALLEY		Length: 12' Per Carton: 5 pieces 60 lineal feet Gross Weight: 50 lbs. <b>Self-cleaning valley</b>
5127	 GABLE CHANNEL		Length: 12' Per Carton: 5 pieces 60 lineal feet Gross Weight: 35 lbs.  <b>Fold-over Gable</b>
5429	 SIDEWALL FLASHING		Length: 12' Per Carton: 5 pieces 60 lineal feet Gross Weight: 35 lbs.  <b>Roof into sidewall flashing</b>

# Great American Shake Steel

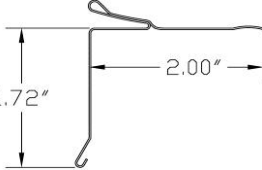
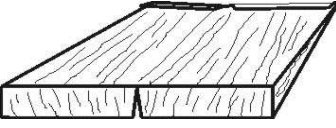
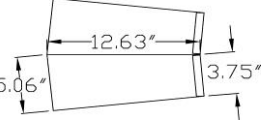
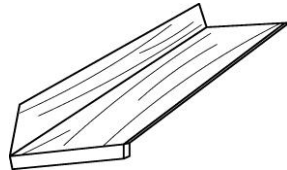
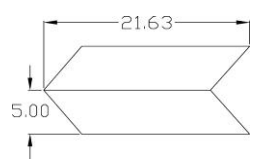
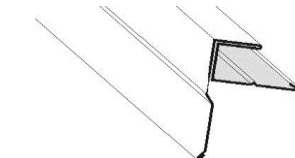
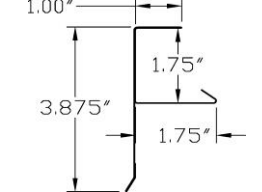
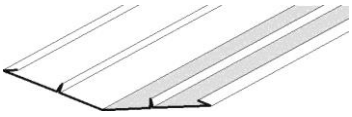
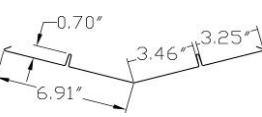
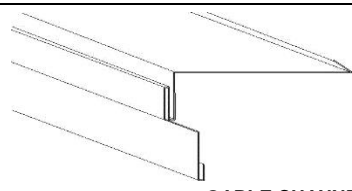
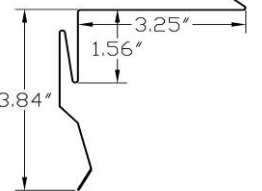
PART NO.	PRODUCT	DIMENSIONS	SPECIFICATIONS & PACKAGING
5150	 FLASHING COIL	Width: 23.75", 50 lineal feet, 1 roll 66 lbs.	

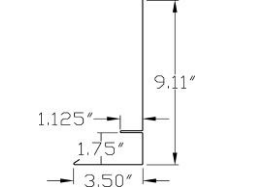
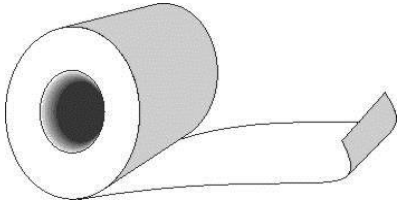
## COLORS AVAILABLE:

Evergreen and Mission Red



*A Division of Isaiah Industries*

8510 Industry Park Dr.

P O Box 701

Piqua, Ohio 45356

Tel. 937-773-9840

Toll-Free: 1-888-705-5656

Sales Office Fax: 937-778-5116

[www.greenamericanhome.com](http://www.greenamericanhome.com)

[info@greenamericanhome.com](mailto:info@greenamericanhome.com)